



www.first4seals.com



Double Rotary

Environmental
Cartridge Mechanical
Seals 302™ Series

AESSEAL Marine plc, Unit 4 Venlo Industrial Estate, Knowles Street, Bradford, BD4 6HA, United Kingdom
Tel: +44 (0) 1274 720775 Fax: +44 (0) 1274 729022
Email: seals@first4seals.com - Web: www.first4seals.com

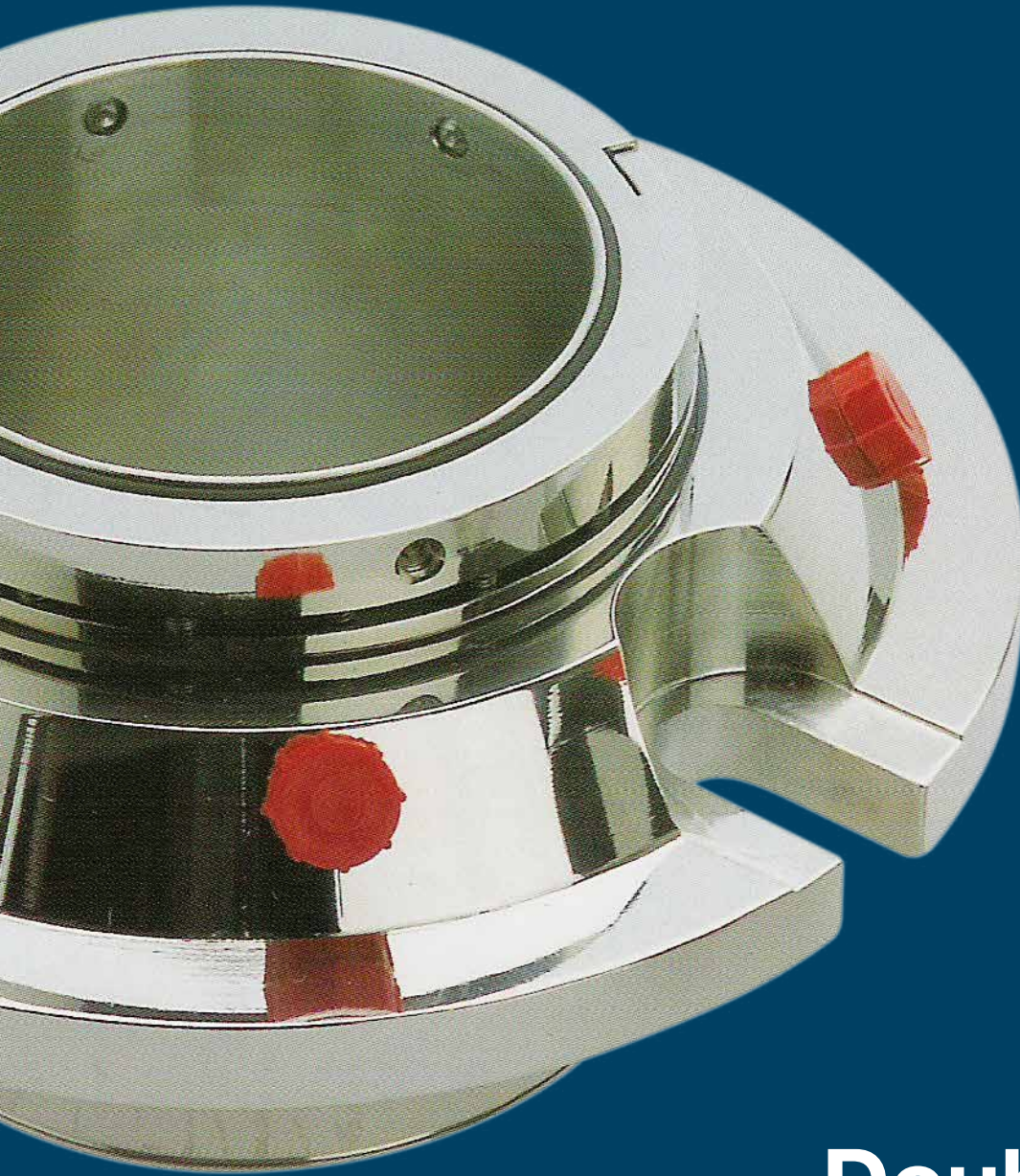

Double Rotary Mechanical Cartridge Seals

To conform to current environmental legislation, double cartridge seals are specified to provide maximum emission control in critical and noxious applications.

The double balanced cartridge seal design uses 50% of the power required by standard unbalanced seals and only 20% of the power required by pump packing.

All packing must leak to survive, whereas seals should be leak free. This reduces both environmental contaminants and disposal costs.

The 302TM is a face-to-face double rotary cartridge seal that has been designed for hazardous and aggressive sealing applications in Chemical and Process Industries. It possesses design features essential for applications where safety is the prime consideration. The patented pumping action allows cool running to be achieved, thereby extending seal life, whilst the double balanced design allows up to 30 bar (440 psi) product or barrier pressure to be accommodated.

302™

Double Mechanical Cartridge Seals



The Green Issue

The 302™ cartridge seal is designed with an external shroud and drain port for safe collection and removal of product and barrier fluid.

302™ cartridge seals can be fully refurbished with most parts being re-used.

As leakage is eliminated corrosion problems to pump, bearing and pump room are all greatly reduced.



302™ Series - Technical Specification

| | | | |
|--------------------|---|--|--|
| Metal Parts | 316 Stainless Steel as standard, other materials also available. | Stationary | Alumina Ceramic, Silicon Carbide or Tungsten Carbide available as standard. |
| Springs | Alloy 276 | Temperature Limits | -30°C to 260°C (-22°F to 500°F) dependent upon specified elastomer and system configuration. |
| O-Rings | Viton® (Fluorocarbon) or Ethylene Propylene (EPR) as standard. Aflas®, Kalrez® and other elastomers available to order. | Pressure Limits - Media and Barrier | 711mm HG Vacuum to 30 Bar (-28" HG - 440 PSI). It is recommended that the barrier pressure is 1 Bar (15 psi) greater than the media. |
| Rotary Face | Carbon, Silicon Carbide or Tungsten Carbide as standard. Antimony Carbon available on request. | | |

As the conditions of use are outside the control of first4seals, the information contained within this brochure is given in good faith but without warranty. The above temperature and pressure limits are individual maximum values for SOFT/HARD seal face combinations only. The values are provided for guidance only and are intended for use by suitably qualified application engineers. It is recommended that all users contact the first4seals Technical Department for advice on any new application.

302™ Series - Design Features

Anti Clog

The dynamic o-ring moves onto a clean area as seal faces wear. Components remain free for longer seal life.

No Fretting of Pump Shaft

The seal internal o-ring is static on the shaft and guaranteed never to fret the pump shaft or sleeve.

Springs Out of Fluid

The Alloy 276 springs are not in the pumped fluid where they could corrode or clog and so remain effective for the whole of the seal life.

Pressure Balanced

The seal is hydraulically balanced in both directions to achieve optimum face loading for high pressure capability and to provide cooler running for longer seal life.

Low Turbulence Wetted Parts

The smooth contours of the wetted surfaces create very little turbulence within the seal cavity for longer lasting seal components in abrasive media use.

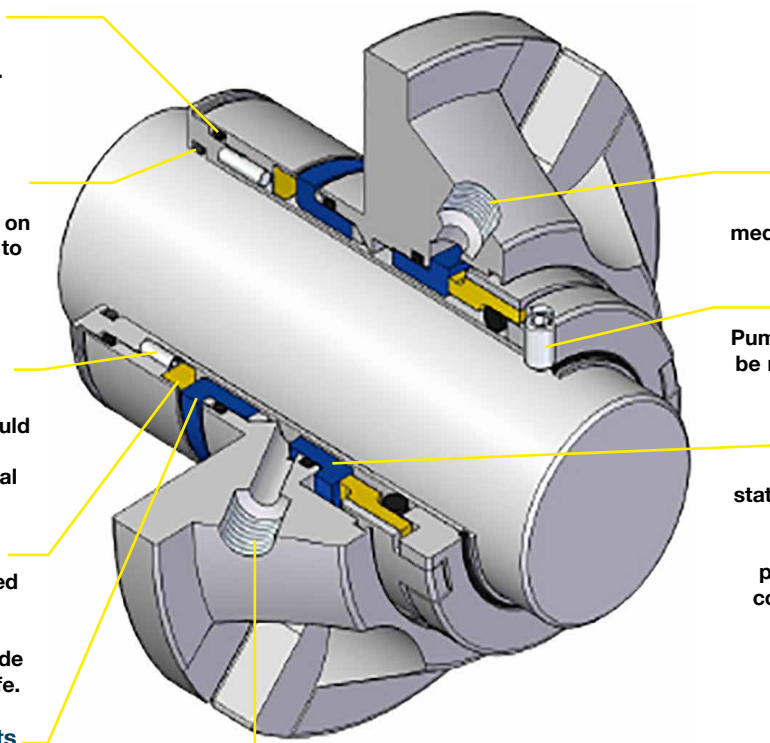

Safety Drain Port

If the outboard seal fails, the media can be drained to disposal or recycling.

External Clamping

Pump efficiency adjustments can be made without dismantling the pump.

Self Aligning Stationary

The patented self aligning stationary eliminates fretting and spring fatigue, ensures good alignment of seal faces and provides a good 'heat sink' for cooler running with heightened face lubricity.

Barrier Ports

Barrier fluid is directed to the rotary surfaces. The unique pumping action also achieves cooler running.



302™ Dimensional Information

4 bolt fixing.
 Supplied with 2 barrier fluid ports
 and a safety drain port (1/4" BSP)

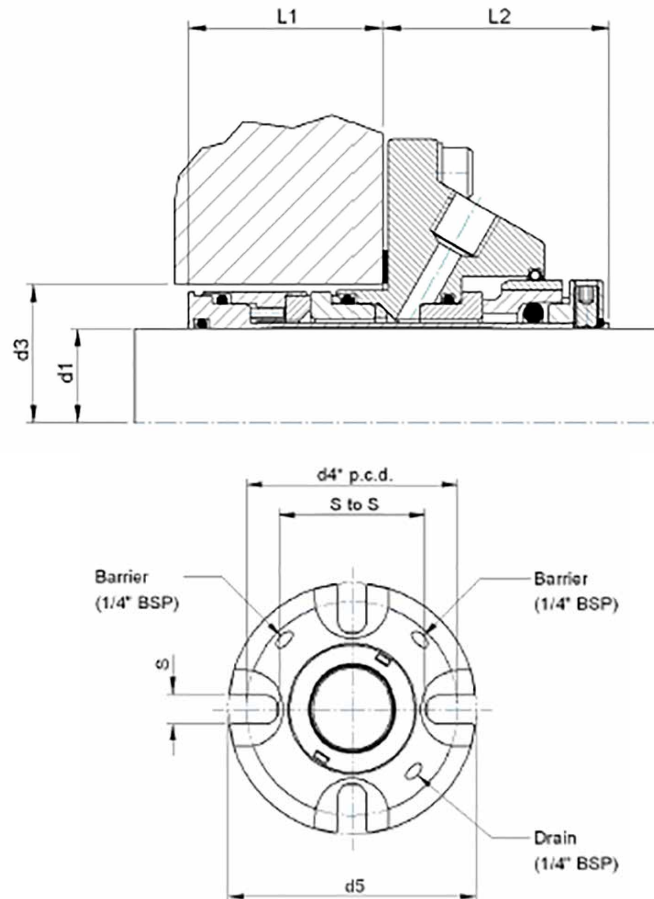

Other single & PCP cartridge seals in the f4s range:

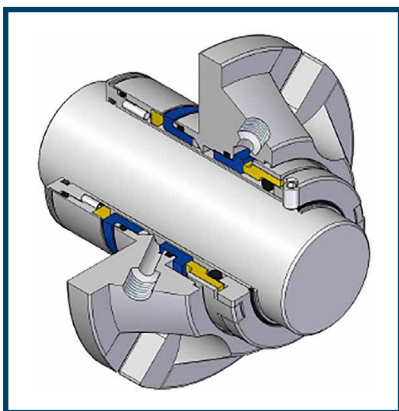

301™ Range

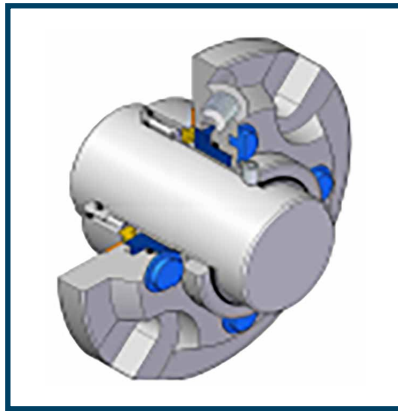

303A™ Range

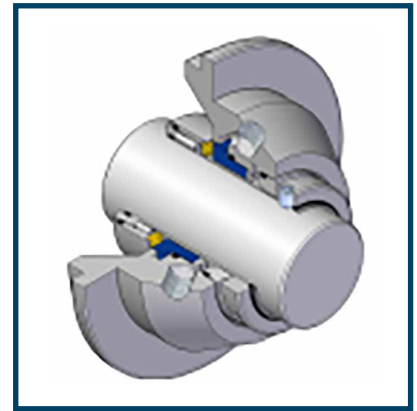

PCP Range

A range of single cartridge seals are available to suit all application needs. Seals to suit progressive cavity pumps (PCP) are also available in single and double formats. See our single rotary literature for further details.

302™ Series - Size Chart

| d1 | d3 | | d4*pcd | | d5 | L1 | L2 | S to S | S |
|-----|--------|--------------|--------------|-------|-------|------|------|--------|------|
| | Metric | S/B I.D. Min | S/B I.D. Max | Min | | | | | |
| 25 | 44.5 | 52.7 | 69.0 | 82.0 | 95.0 | 44.0 | 51.0 | 59.0 | 12.7 |
| 28 | 47.6 | 55.7 | 72.0 | 85.0 | 100.0 | 44.0 | 51.0 | 62.0 | 12.7 |
| 30 | 50.8 | 58.7 | 75.0 | 90.0 | 105.0 | 44.0 | 51.0 | 65.0 | 12.7 |
| 33 | 50.8 | 58.7 | 75.0 | 90.0 | 105.0 | 44.0 | 51.0 | 65.0 | 12.7 |
| 35 | 54.0 | 61.7 | 78.0 | 95.0 | 110.0 | 44.0 | 51.0 | 68.0 | 12.7 |
| 38 | 57.2 | 66.7 | 85.0 | 100.0 | 120.0 | 46.0 | 54.0 | 73.0 | 15.9 |
| 40 | 60.3 | 69.7 | 88.0 | 100.0 | 120.0 | 46.0 | 54.0 | 76.0 | 15.9 |
| 43 | 63.5 | 72.7 | 91.0 | 115.0 | 135.0 | 46.0 | 54.0 | 79.0 | 15.9 |
| 45 | 63.5 | 72.7 | 91.0 | 115.0 | 135.0 | 46.0 | 54.0 | 79.0 | 15.9 |
| 48 | 66.7 | 76.7 | 95.0 | 115.0 | 135.0 | 46.0 | 54.0 | 83.0 | 15.9 |
| 50 | 69.9 | 79.7 | 95.0 | 115.0 | 135.0 | 46.0 | 54.0 | 83.0 | 15.9 |
| 53 | 73.0 | 82.7 | 101.0 | 130.0 | 150.0 | 46.0 | 54.0 | 89.0 | 15.9 |
| 55 | 76.2 | 85.7 | 104.0 | 145.0 | 165.0 | 46.0 | 54.0 | 92.0 | 15.9 |
| 60 | 79.4 | 88.7 | 107.0 | 145.0 | 165.0 | 46.0 | 54.0 | 95.0 | 15.9 |
| 65 | 88.9 | 107.7 | 130.0 | 150.0 | 175.0 | 52.0 | 60.0 | 114.0 | 17.5 |
| 70 | 92.0 | 111.7 | 134.0 | 150.0 | 175.0 | 52.0 | 60.0 | 118.0 | 17.5 |
| 75 | 98.4 | 117.7 | 140.0 | 165.0 | 190.0 | 52.0 | 60.0 | 124.0 | 17.5 |
| 80 | 101.5 | 120.7 | 143.0 | 165.0 | 190.0 | 52.0 | 60.0 | 127.0 | 17.5 |
| 85 | 107.9 | 126.7 | 152.0 | 175.0 | 200.0 | 52.0 | 60.0 | 133.0 | 20.6 |
| 90 | 114.3 | 133.7 | 159.0 | 196.0 | 215.0 | 52.0 | 60.0 | 140.0 | 20.6 |
| 95 | 117.5 | 136.7 | 162.0 | 196.0 | 215.0 | 52.0 | 60.0 | 143.0 | 20.6 |
| 100 | 130.0 | 155.7 | 181.0 | 211.0 | 230.0 | 55.0 | 66.0 | 162.0 | 20.6 |
| 105 | 133.0 | 155.7 | 181.0 | 211.0 | 230.0 | 55.0 | 66.0 | 162.0 | 20.6 |
| 110 | 139.7 | 164.7 | 190.0 | 221.0 | 240.0 | 55.0 | 66.0 | 171.0 | 20.6 |
| 115 | 142.9 | 164.7 | 190.0 | 221.0 | 240.0 | 55.0 | 66.0 | 171.1 | 20.6 |
| 120 | 149.2 | 174.7 | 200.0 | 231.0 | 250.0 | 55.0 | 66.0 | 181.0 | 20.6 |
| 125 | 155.6 | 174.7 | 200.0 | 231.0 | 250.0 | 55.0 | 66.0 | 181.0 | 20.6 |

| d1 | d3 | | d4*pcd | | d5 | L1 | L2 | S to S | S |
|-------|----------|--------------|--------------|-------|-------|-------|-------|--------|-------|
| | Imperial | S/B I.D. Min | S/B I.D. Max | Min | | | | | |
| 1.000 | 1.752 | 2.073 | 2.717 | 3.228 | 3.740 | 1.732 | 2.008 | 2.323 | 2.500 |
| 1.125 | 1.874 | 2.191 | 2.835 | 3.346 | 3.937 | 1.732 | 2.008 | 2.441 | 0.500 |
| 1.250 | 2.000 | 2.309 | 2.953 | 3.543 | 4.134 | 1.732 | 2.008 | 2.559 | 0.500 |
| 1.375 | 2.126 | 2.427 | 30.71 | 3.740 | 4.331 | 1.732 | 2.008 | 2.677 | 0.500 |
| 1.500 | 2.252 | 2.624 | 3.346 | 3.937 | 4.724 | 1.811 | 2.126 | 2.874 | 0.626 |
| 1.625 | 2.374 | 2.742 | 3.465 | 3.937 | 4.724 | 1.811 | 2.126 | 2.992 | 0.626 |
| 1.750 | 2.500 | 2.860 | 3.583 | 4.528 | 5.315 | 1.811 | 2.126 | 3.110 | 0.626 |
| 1.875 | 2.626 | 3.018 | 3.740 | 4.528 | 5.315 | 1.811 | 2.126 | 3.268 | 0.626 |
| 2.000 | 2.752 | 3.136 | 3.858 | 5.118 | 5.906 | 1.811 | 2.126 | 3.386 | 0.626 |
| 2.125 | 2.874 | 3.254 | 3.976 | 5.118 | 5.906 | 1.811 | 2.126 | 3.504 | 0.626 |
| 2.250 | 3.000 | 3.372 | 4.094 | 5.709 | 6.496 | 1.811 | 2.126 | 3.622 | 0.626 |
| 2.375 | 3.126 | 3.490 | 4.213 | 5.709 | 6.496 | 1.811 | 2.126 | 3.740 | 0.626 |
| 2.500 | 3.374 | 4.120 | 5.000 | 5.906 | 6.890 | 2.047 | 2.362 | 4.370 | 0.689 |
| 2.625 | 3.500 | 4.238 | 5.118 | 5.906 | 6.890 | 2.047 | 2.362 | 4.488 | 0.689 |
| 2.750 | 3.622 | 4.396 | 5.276 | 5.906 | 6.890 | 2.047 | 2.362 | 4.646 | 0.689 |
| 2.875 | 3.748 | 4.514 | 5.394 | 6.496 | 7.480 | 2.047 | 2.362 | 4.764 | 0.689 |
| 3.000 | 3.874 | 4.632 | 5.512 | 6.496 | 7.480 | 2.047 | 2.362 | 4.885 | 0.689 |
| 3.125 | 3.996 | 4.750 | 5.630 | 6.496 | 7.480 | 2.047 | 2.362 | 5.000 | 0.689 |
| 3.250 | 4.122 | 4.868 | 5.866 | 6.890 | 7.874 | 2.047 | 2.362 | 5.118 | 0.811 |
| 3.375 | 4.248 | 4.986 | 5.984 | 6.890 | 7.874 | 2.047 | 2.362 | 5.236 | 0.811 |
| 3.500 | 4.374 | 5.144 | 6.142 | 6.890 | 7.874 | 2.047 | 2.362 | 5.394 | 0.811 |
| 3.625 | 4.500 | 5.262 | 6.260 | 7.717 | 8.465 | 2.047 | 2.362 | 5.512 | 0.811 |
| 3.750 | 4.626 | 5.380 | 6.378 | 7.717 | 8.465 | 2.047 | 2.362 | 5.630 | 0.811 |
| 3.875 | 4.748 | 5.498 | 6.496 | 7.717 | 8.465 | 2.047 | 2.362 | 5.748 | 0.811 |
| 4.000 | 5.118 | 6.128 | 7.126 | 8.307 | 9.055 | 2.165 | 2.598 | 6.378 | 0.811 |
| 4.125 | 5.236 | 6.128 | 7.126 | 8.307 | 9.055 | 2.165 | 2.598 | 6.378 | 0.811 |
| 4.250 | 5.374 | 6.128 | 7.126 | 8.307 | 9.055 | 2.165 | 2.598 | 6.378 | 0.811 |
| 4.375 | 5.500 | 6.482 | 7.480 | 8.701 | 9.449 | 2.165 | 2.598 | 6.732 | 0.811 |
| 4.500 | 5.626 | 6.482 | 7.480 | 8.701 | 9.449 | 2.165 | 2.598 | 6.732 | 0.811 |
| 4.625 | 5.752 | 6.482 | 7.480 | 8.701 | 9.449 | 2.165 | 2.598 | 6.732 | 0.811 |
| 4.750 | 5.874 | 6.876 | 7.874 | 9.094 | 9.843 | 2.165 | 2.598 | 7.126 | 0.811 |
| 4.875 | 6.000 | 6.876 | 7.874 | 9.094 | 9.843 | 2.165 | 2.598 | 7.126 | 0.811 |
| 5.000 | 6.126 | 6.876 | 7.874 | 9.094 | 9.843 | 2.165 | 2.598 | 7.126 | 0.811 |

*Based on the largest bolt diameter (specials can be produced)

f4s25™ & f4s25CC™ Systems:

A range of seal support systems including a 25 litre (6.6 US Gallons) vessel with or without cooling coil to cover demanding applications, offering fast and problem free installation on site. These are supplied with all the necessary components and fittings. Various hose kits are available including polyamide and flexible braided stainless steel. Available to US markets only.

f4s10™ & f4s10CC™ systems:

As per f4s25 but includes a 10 litre (2.6 US Gallons) vessel with or without cooling coil to cover most standard or lower temperature applications.

Standard Buffer system:

May be used unpressurised to provide cooling on medium temperature applications, to prevent crystallisation of aqueous solutions, or to provide protection from dry-running damage.

This includes:

- 1 off vessel
- 1 off ball/drain valve
- 1 off level gauge/sight glass
- 1 off ball/fill valve
- 1 off polyamide pipe kit with fittings

Standard Water Retention Systems:

Water retention systems are connected directly to a suitable clean water supply (subject to local regulations) to form a low maintenance, high reliability barrier fluid system. In normal operation the supply pressurises the vessel, but negligible water is drawn. The 'Thermosyphon' effect (natural convection) ensures the seal is kept cool.

When the flow indicator eventually shows water is being drawn from the supply, this indicates the need to consider seal replacement. In the meantime the integrity of the barrier is maintained to extend seal life and prevent any loss of product.

This includes:

- 1 off vessel
- 1 off ball/drain valve
- 1 off level gauge/sight glass
- 1 off pressure gauge
- 1 off water regulator
- 1 off water supply connection
- 1 off non return valve
- 1 off flow indicator
- 1 off polyamide pipe kit with fittings
- 1 off 3 way valve

Standard Gas/Air Pressurised Systems:

Pressure systems are partially filled with a suitable fluid then pressurised via a connection to a factory air or nitrogen supply. Alternatively, the system can be pressurised from a mobile nitrogen cylinder. Again, the seal is cooled by the 'Thermosyphon' effect.

This includes:

- 1 off vessel
- 1 off ball/drain valve
- 1 off level gauge/sight glass
- 1 off ball/fill valve
- 1 off air/nitrogen regulator
- 1 off relief valve
- 1 off polyamide pipe kit with fittings
- 1 off pressure gauge
- 1 off 3 way valve

Vessel Code:

The f4s10™ & f4s25™ vessels are designed and manufactured in accordance with ASME VIII Div1 (not stamped) and comply with PED97/23/EC.

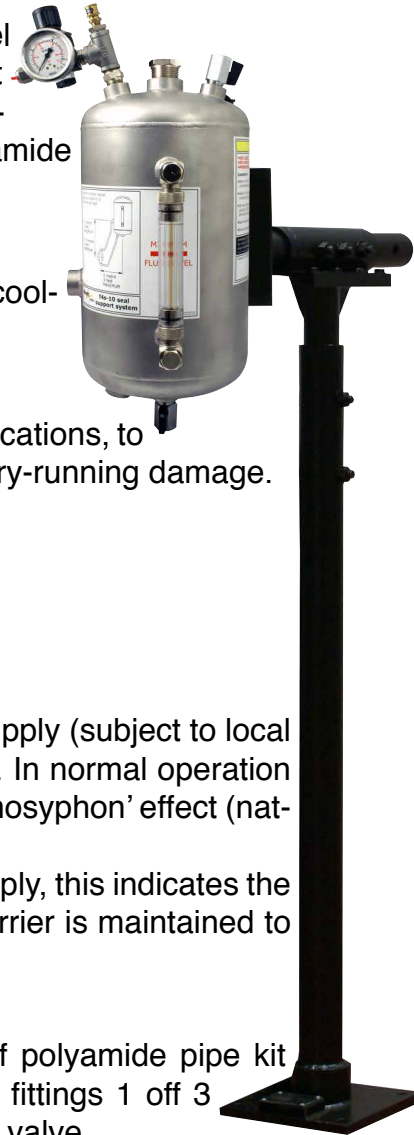

f4s200™ Double Stationary Cartridge Seal

Double stationary seals available to suit hazardous and aggressive applications. See f4s200™ series literature for further details.

Mechanical Seal Repairs **first** seals™ Division

In 2016 we invested in new premises and are proud to have a world class seal assembly and repair workshop. This facility includes a state-of-the-art stock management system incorporating automated carousels in addition to individual booths to segregate workshop processes.

Seal assessment

Each seal is cleaned to remove any chemicals or hazardous materials upon arrival and then individually inspected and assessed. The assessment process determines which components require replacement or refurbishment in order to generate an accurate and cost effective repair quotation. Materials specifications are identified through understanding of seal construction, operation and application.

Quotation

All repair quotations are based on specific parts that require refurbishment or replacement. This method is used to reduce repair costs and provide the most economic method of restoring a mechanical seal back to a usable condition.

Seal refurbishment

The refurbishment process restores seals to their original functionality at a fraction of the cost of replacement hardware. Our refurbishment service is available for all standard first4seals products and those of many leading manufacturers, to help prolong a mechanical seal's life span. We are able to repair competitor brands such as: Eagle Burgmann®, Chesterton®, Flowserve®, John Crane® and many more.

We are able to design and reverse engineer competitor components which may have failed in service. Components are modelled using state-of-the-art Computer Aided Design software to produce an accurate model. Components are manufactured using multi-axis CNC machines from a range of materials including standard 316L Stainless Steel, exotic alloys, PTFE and Carbon.

Quality

Quality and customer service are the highest priority and our business is certified to ISO 9001:2015. All repairs are carried out by experienced workshop technicians and monitored by our Technical Team to provide a service which offers a cost-effective and environmentally sound alternative to purchasing new seals. Each seal is pressure tested before it is sent back to the customer. Testing ensures that the seal is in full working order and will perform correctly when installed back into service.



Single Spring Seals



Component Seals



MV™ Single Rotary Cartridge Seals



301™/303A™ Single Rotary Cartridge Seals



302™ Double Rotary Cartridge Seals



f4s100™ Single Stationary Cartridge Seals



f4s200™ Double Stationary Cartridge Seals



Seal Support Systems



THIS DOCUMENT IS DESIGNED TO PROVIDE DIMENSIONAL DATA AND IS NOT AN INDICATION OF AVAILABILITY FROM STOCK. SOME DESIGNS MAY BE SUBJECT TO MINIMUM ORDER QUANTITIES AND MANUFACTURING LEAD TIMES.



FM61505

UK Sales and Technical Advice:
 AESSEAL Marine plc
 Unit 4 Venlo Industrial Estate,
 Knowles Street, Bradford,
 BD4 6HA
Tel: +44 (0)1274 720775
Fax: +44 (0)1274 729022
Email: seals@first4seals.com
Web: www.first4seals.com

Distributed by:

